

(No Model.)

2 Sheets—Sheet 1.

G. WOOD.

LATHE FOR TURNING SPIRALS.

No. 352,901.

Patented Nov. 16, 1886.

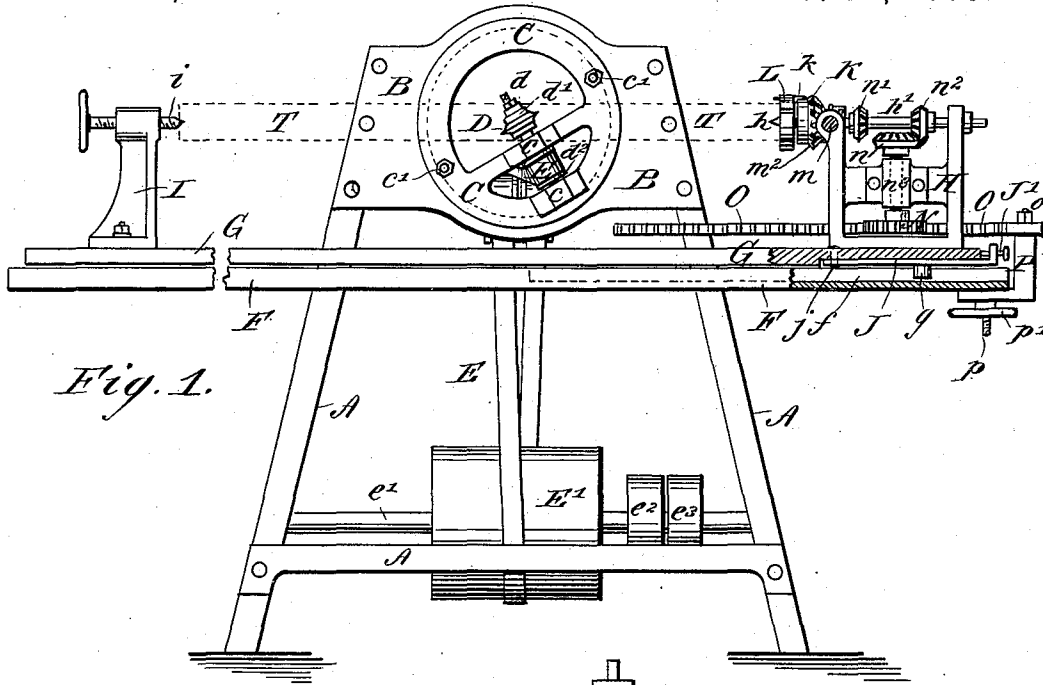

Fig. 1.

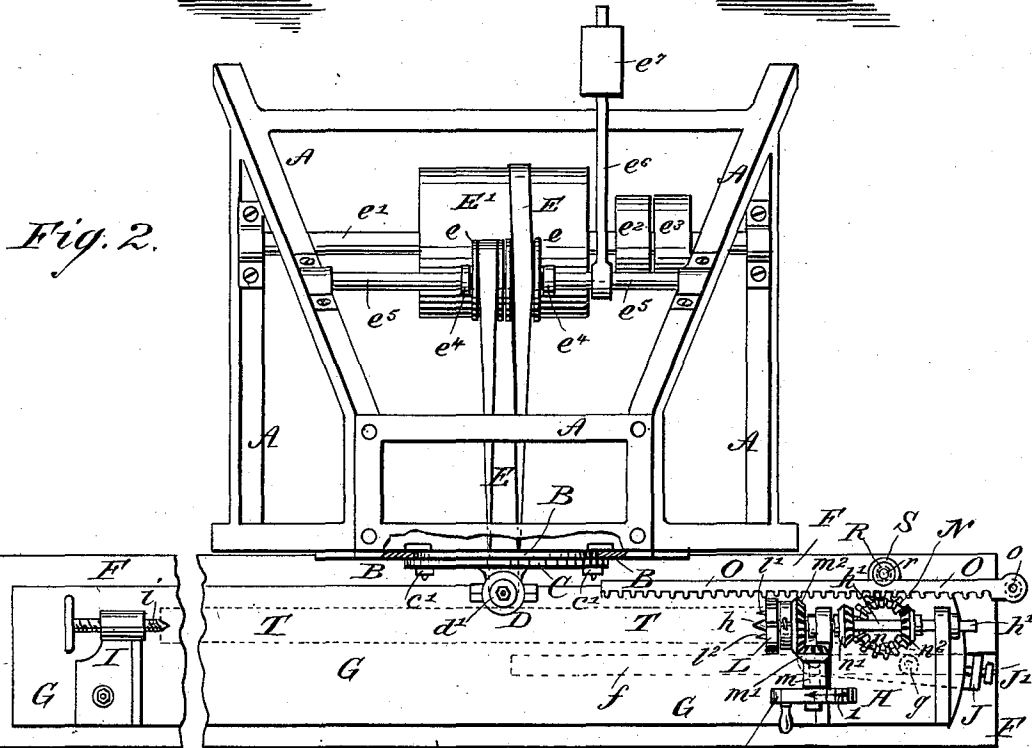
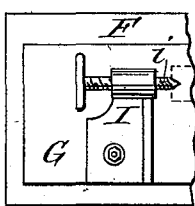

Fig. 2.



WITNESSES:

Donn Twitchell.
W. Sedgwick

INVENTOR:

G. Wood

BY

Munn & Co.
ATTORNEYS.

(No Model.)

2 Sheets—Sheet 2.

G. WOOD.

LATHE FOR TURNING SPIRALS.

No. 352,901.

Patented Nov. 16, 1886.

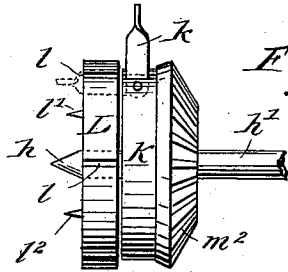
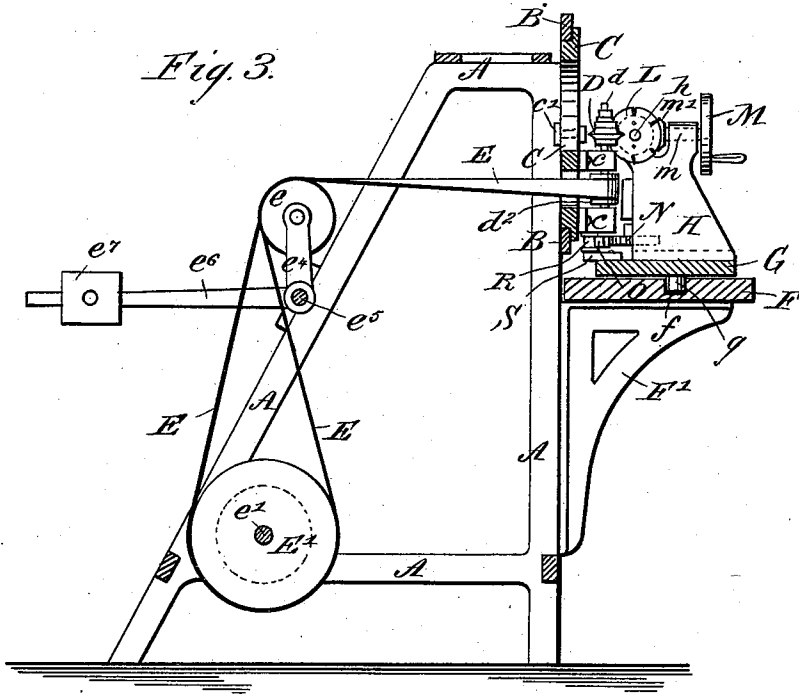

Fig. 4.

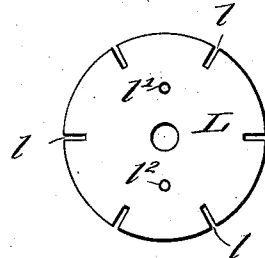
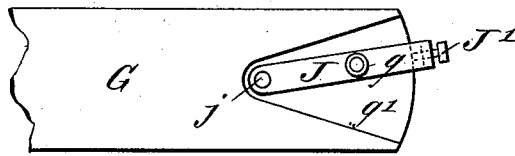

Fig. 5.

Fig. 6.



WITNESSES:

Donn Twitchell
W. Sedgwick

INVENTOR:

G. Wood

BY

Munn & Co.

ATTORNEYS.

UNITED STATES PATENT OFFICE.

GEORGE WOOD, OF PHILADELPHIA, PENNSYLVANIA.

LATHE FOR TURNING SPIRALS.

SPECIFICATION forming part of Letters Patent No. 352,901, dated November 16, 1886.

Application filed March 11, 1886. Serial No. 194,840. (No model.)

To all whom it may concern:

Be it known that I, GEORGE WOOD, of Philadelphia, (Germantown,) in the county of Philadelphia and State of Pennsylvania, have invented a new and Improved Machine for Working Spiral Twist-Forms, of which the following is a full, clear, and exact description.

My invention has for its object to provide a simple, efficient, and easily-operated machine adapted for cutting spiral twist moldings or forms on the exterior surfaces of turned work—such as stair-balusters and newel-posts, and the like—and whether the work be cylindrical or tapering or curved and irrespective of the diameter or length of the work.

The invention consists in certain novel features of construction and combinations of parts of the machine, all as hereinafter fully described and claimed.

Reference is to be had to the accompanying drawings, forming a part of this specification, in which similar letters of reference indicate corresponding parts in all the figures.

Figure 1 is a front elevation, partly broken away and in section, of my improved machine for working twist-forms. Fig. 2 is a plan view thereof, also broken away and in section. Fig. 3 is a vertical central sectional elevation of the machine. Fig. 4 is an enlarged detail edge view of the dividing-wheel at the head-stock and its latch-bar and connected driving-gear wheel. Fig. 5 is a face view of the dividing-wheel; and Fig. 6 is an under side view of the end of the movable bed or carriage of the machine next the head-stock.

The frame A of the machine may have any approved construction fitting it for support of the working-parts, but it is made, preferably, with a vertical front, to which the face-plate B is fixed, and with sloping back and side parts, as clearly shown in the drawings. To the face-plate B, and in a circular opening thereof, there is fitted snugly, but movably, the frame C, which has bearings *c c*, in which is journaled a spindle, *d*, which carries the cutters D, which may have any peripheral or edge contour to work beaded, reeded, fluted, or other forms in spiral twists of any pitch on turned baluster or newel rods or posts, as hereinafter more fully explained, the cutters being clamped between collars *d' d'*, which determine the depth to or at which the cutters work.

The cutters D are journaled in the frame C, so that at whatever angle their spindle *d* may be set with the horizon by turning the frame C in the face-plate B and fastening it to the face-plates by the screws or bolts *c' c'* the transverse center of the acting edges of the cutters always will operate directly at the center or axis of motion of the cutter-frame.

On the cutter-spindle *d* is fixed a pulley, *d'*, from which a belt, E, leads over tightener-pulleys *e e* to a drum, E', on a shaft, *e'*, journaled in the frame A, and said shaft has tight and loose pulleys *e'' e''*, from which a driving-belt (not shown) passes to a pulley on an adjacent shaft for giving motion to the cutters. The guide-pulleys E' are journaled to short arms *e''*, which are fixed to a shaft, *e''*, journaled on frame A, and a longer arm, *e''*, on shaft *e''* supports an adjustable weight, *e''*, which carries the pulleys *e e* outward, to hold the driving-belt E taut, irrespective of the angle to which the cutter drive-pulley *d'* may be inclined to either side in adjusting the cutters for making right or left hand spiral twists.

The main work-bed F of the machine is fixed to brackets F', which in turn are fixed to the frame A, and the carriage G, on which the head-stock H and tail-stock I are held, is laid loosely on top of the fixed bed F. A lever, J, is pivoted at *j* to the carriage G, and within a bottom recess, *g'*, thereof, and carries an anti-friction roller, *g*, which enters a longitudinally-ranging groove, *f*, made in or through the bed F; hence the end of the carriage G which supports the tail-stock I may be freely swung or slid on the bed F and on the roller *g* as a fulcrum, to carry the work to and from the cutters D, and at the same time the carriage is free to be moved along the bed F to feed the work along in front of the cutters. The outer end of the lever J is bent upward and receives a set-screw, J', which may be set in against the curved end of the carriage G to hold the roller *g* in any necessary relation to the transverse center of the carriage either in front or rear of said center, for holding the center *h* of the head-stock spindle *h'* adjusted for a distance from the cutters D equal to one-half the diameter of the work being operated on by the cutters.

The head-stock H is fixed to the carriage G, and the tail-stock I is adjustable along the car-

riage to accommodate the length of the work held between the centering-screw i of the tail-stock I and the centering devices on the head-stock, presently described. A live-spindle, h' , 5 journaled in opposite end uprights on the head-stock H, has fixed to its inner end a head-block, K, through which the spindle projects to form the work-holding center h and give support also to a dividing wheel or disk, L, 10 which may revolve freely on the spindle h' , except when a latch-lever, k , pivoted to head-stock K, is swung down or over into one of the peripheral transverse slots l of the wheel L, at which time the wheel L must rotate with the head-stock. The dividing-wheel has op- 15 posite pins or teeth, l' l'' , which enter the end of the work and carry it around freely on the center h when the latch k is disengaged from wheel L, and cause the work to be carried 20 around with the wheel L, head-stock K, and spindle h' when the latch is engaged with the dividing-wheel.

The wheel L shown has six evenly-spaced peripheral notches, but may have a lesser or 25 greater number as the maximum number of spiral cuts to be made in turned rods or bars of different diameters may require.

In a suitable standard on the head-stock H there is journaled at right angles to the spindle h' a shaft, m , to the inner end of which is 30 fixed a bevel-pinion, m' , which meshes with a bevel-pinion or gear-wheel, m'' , formed on or fixed to the head-block K, and at its outer end the shaft m carries fixedly a hand-wheel, M, 35 by turning which motion is given to the spindle h' and connected parts.

On the spindle h' there are arranged a couple of bevel-pinions, n' n'' , either of which may be engaged with a bevel gear-wheel, n , which 40 is fixed to a vertical shaft, n^3 , journaled to a cross-bar of the head-stock H, and to the lower end of the shaft n^3 there is fixed a spur-gear wheel, N, which is adapted to engage the teeth of a rack-bar, O, which is pivoted at 45 one end on a pin, o , to the upturned end of an angle-arm, P, which is pivotally adjustable on a screw-bolt, p , fixed to the under side of the stationary bed F, and a hand-wheel nut, p' , on bolt p may be tightened to hold the angle- 50 arm P to place for causing the rack-bar O to engage spur-gear wheels N of different sizes placed on the vertical shaft n^3 , said wheels N being interchangeable to govern the speed of rotation of the spindle h' and the rotating 55 work, in accordance with the diameter of the work and the pitch of the spiral moldings to be cut thereon.

A peripherally-grooved roller, R, is journaled on a vertical pin or stud, r , on an arm, 60 S, held to the movable bed-plate F in such manner as to allow the roller to be set against the back edge of the rack-bar O, to hold it in gear with a spur-wheel, N, of any size, held on the vertical shaft n^3 in the head-stock H.

55 It will be noticed that a straight line drawn between the centers h i of the head and tail stocks—or, in other words, the horizontal axis

of rotation of the work—will always be in the same horizontal plane as the center of the periphery of the cutters D. 70

The operation of the machine is as follows: The attendant will set the lever J to cause its roller g to hold the carriage G and the work-holding centers thereon in proper position to suit the diameter of the work—a turned baluster, T, for instance, as shown in dotted lines— 75 and if a right-hand spiral molding is to be cut in the work the cutter-shaft d will be set by turning the frame C around to incline the cutter-shaft d more or less from a vertical position downward toward the right hand, as in Fig. 1, according to the pitch of the spiral, made necessary by the diameter of the work and the number of members it is desired to mold in or on it by the cutters. The latch k being swung upward 85 clear of the dividing-wheel L, as in full lines in Fig. 4, the work will be placed in the centers h i of the head and tail stocks and the teeth l' l'' of the wheel L will enter the end of the work, so that it may carry the dividing- 90 wheel around with it as the work turns on the centers h i ; and it is at this time that the first turned piece of any given lot of balusters or the like will be run lightly against the edge of the non-rotating cutters D by pushing the 95 carriage G inward at the tail-stock end as the hand-wheel M is turned to cause the inter-meshing gears n^2 n to traverse the carriage G along the bed F, and whereby the work will be marked by the cutters to determine the ac- 100 curacy of the set of the cutters as to the pitch of the spiral, it being understood that the proper wheel N has been adjusted to the vertical shaft n^3 and the guide-roller R has also been set to hold the rack O in gear with 105 the wheel N. The above adjustments having been made the cutters D will be started and the latch k will be set into one of the slots l of the dividing-wheel, and the carriage will be moved by operating the hand-wheel M in di- 110 rection of the arrow 1 in Fig. 2 by the right hand, while the left hand is free to press the work to the cutters by pushing the carriage G inward as it swings on the roller g , and the work will gradually be fed toward the right 115 hand as the first spiral cut is made in the work from the head-stock toward the tail-stock, and when this cut is completed and while the cutters are rotating the carriage will be swung backward to carry the work away from the 120 cutters and the latch k will be raised from the dividing-wheel, which will be turned around a distance of one or more notches l , as may be required, and the latch will be engaged with another notch of the dividing-wheel and the 125 work will again be fed to and along the cutters, as before, for making the second and any following number of spiral cuts in it, as required. As the collars d' d' limit the depth of working of the cutters D, and as the tail- 130 stock end of the carriage G is free to swing inward or outward on its fulcrum g , it is obvious that tapering work may also be cut spirally for the whole or any part of its length, and

whether the work be cylindrical or tapering or curved it may be pressed to the cutters to commence and end a spiral cut of any length at any part of the work—in other words, any part of the work which is to be ornamented by carving or otherwise or left plain may be held away from the cutter at the pleasure of the operator.

When left-hand spiral moldings or cuts are to be produced on the work, the frame C will be set to hold the cutter-spindle d inclined downward toward the left hand or in the reverse direction to that shown in Fig. 1, and the pinion n^2 will be disengaged from the bevel-gear n and the pinion n' will be engaged therewith, and the hand-wheel M will be turned by the operator in the reverse direction to that indicated by the arrow on the wheel, to feed the work along the cutters, as will readily be understood.

If desired, the face of the frame-plate B around the upper half of the cutter-frame C may be graduated in any approved way, so that a pointer fixed to the frame C in line with the cutter-shaft d may indicate along the scale the set of the cutters for work of any standard size.

Having thus fully described my invention, I claim as new and desire to secure by Letters Patent—

1. In a machine for working spiral-twist forms, the combination of a main frame, a face-plate fixed thereon, a cutter-frame fitted to turn in or adjustably on the face-plate, a spindle journaled radially in the cutter-frame, cutters on said spindle operating at the axis of motion or adjustment of the cutter-frame, means, substantially as specified, for rotating the cutters, a work-bed fixed to the main frame, a carriage fulcrumed at one end to the work-bed and free to move toward or from the cutters at its other end, and movable also along the bed, and head and tail stocks mounted on the carriage and provided with work-holding centers set in alignment horizontally with the axis of motion or adjustment of the cutter-holding frame, substantially as and for the purposes herein set forth.

2. In a machine for working spiral-twist forms, the combination of a frame, A, face-plate B, cutter-frame C, spindle d , and cutters D thereon, arranged substantially as specified, and a fixed work-bed, F, slotted at f , a carriage, G, laid loosely on the bed F, and having a guide or fulcrum-pin or roller, g , at or near one end and adapted to the bed-slot f , and head and tail stocks on the carriage, having work-holding centers set in alignment horizontally with the axis of motion or adjustment of the cutter-frame C, substantially as and for the purposes herein set forth.

3. In a machine for working spiral-twist forms, the combination, with the frame A and the fixed work-bed F, slotted at f , of a carriage, G, laid loosely on the bed and provided with work-holding head and tail stocks, a lever, J, fulcrumed at j to the carriage, a pin or roller,

g , on lever J, and adapted to slot f of bed F, and a clamping device, as a set-screw, J', adapted to hold the carriage G and lever J and its roller g at various adjustments relatively to the bed F and its slot f , substantially as and for the purposes herein set forth.

4. In a machine for working spiral-twist forms, the combination of the frame A, work-bed F, the carriage G, loose on bed F and fulcrumed thereto at one end, and adapted also to move along the bed, head and tail stocks H I on the carriage, a work-holding spindle, h' , journaled in head-stock H, a vertical shaft, n^3 , also journaled in the head-stock, a gear-wheel or pinion, n^2 , on spindle h' , gear-wheels n N on the shaft n^3 , and a rack-bar held to the bed F, and with which the gear-wheel N meshes, substantially as shown and described, whereby as the spindle h' is turned the carriage G will be moved along the bed and may be moved freely inward or outward at the tail-stock end, as and for the purposes herein set forth.

5. In a machine for working twist forms, the combination of the frame A, work-bed F, the carriage G, loose on bed F and fulcrumed thereto at one end, and adapted to move along the bed, work-holding head and tail stocks H I on the carriage, a spindle, h' , journaled in head-stock H, a vertical shaft, n^3 , also journaled in the head-stock, a gear-wheel, n^2 , on spindle h' , a gear-wheel, n , on the shaft n^3 , a rack-bar held to the bed F, and with which the wheel N meshes, a gear-wheel, m^2 , on spindle h' , a shaft, m , journaled in the head-stock, a pinion, m' , on shaft m and meshing with pinion m^2 , and a hand-wheel, M, on shaft m , substantially as and for the purposes herein set forth.

6. In a machine for working spiral-twist forms, the combination of the frame A, work-bed F, slotted at f , the carriage G, loose on bed F and carrying head and tail stocks H I, a lever, J, fulcrumed at j to the carriage, a pin or roller, g , on lever J and adapted to the bed-slot f , a clamping device, as a set-screw, J', adapted to hold the carriage G at various adjustments, a rack-bar, O, held adjustably at one end to the bed F, an adjustable guide, R S, held to the carriage, and adapted to give back-support to the rack-bar O, a spindle, h' , journaled in the head-stock H, a shaft, n^3 , journaled vertically in the head-stock, a drive-wheel, n , on shaft n^3 , interchangeable gears N on shaft n^3 and adapted to mesh with the rack O, and a gear-wheel or pinion, n^2 , on the spindle h' , adapted to mesh with the gear-wheel n , substantially as and for the purposes herein set forth.

7. In a machine for working twist-forms, the combination of a frame, A, face-plate B, adjustable cutter-frame C, spindle d , and cutters D thereon, arranged and operating substantially as specified, and a work-bed, F, a carriage, G, loose on bed F and fulcrumed thereto at one end, and adapted to move along the bed, head and tail stocks H I on the car-

riage, a spindle, h' , journaled in head-stock H, a vertical shaft, n^3 , journaled in the head-stock, a gear-wheel, n , on shaft n^3 , pinions n^2 on spindle h' , adapted to be engaged separately with the wheel n , a gear-wheel, N, on shaft n^3 , and a rack-bar held to the bed F, and with which the wheel N meshes, substantially as shown and described, whereby upon engaging the pinions n^2 n' , respectively, with the

wheel n when the spindle h' is rotated the work may be revolved in reverse directions for cutting a right and left hand spiral thereon when pressed to the cutters as the carriage moves along the bed F, as herein set forth.

GEORGE WOOD.

Witnesses:

GEORGE WM. WOOD,
S. A. GREENE.